



LETTER LOCKER SURFACE MOUNT INSTALLATION INSTRUCTIONS

FLAG INSTALLATION:

Install the flag on the right side of the mailbox by placing the nylon washers onto the 3/4" long machine screws. Now insert the screw & washers thru the flag, thru the brass bushing, and then thru the side of the mailbox. Place nuts on the inside of box and tighten, using a 3/8" wrench and a Philips screwdriver to tighten. (Figure A)

LOCK AND KEYS:

The Letter Locker comes with 3 gold keys for standard locks and 2 silver keys with the upgrade (Medeco deadbolt) lock. **It is important to note that it is not the responsibility of mail carriers to open mailboxes that are locked, accept keys for this purpose, or to lock mailboxes after delivery of the mail.**

INSTALLATION REGULATION:

* Curbside mailboxes must be placed so that they may be safely and conveniently serviced by the mail carrier, without leaving their vehicles, and must be located on the right hand side of the road in the direction of travel of the carrier. Carriers are subject to the same traffic laws and highway regulations as are other motorists.

**** Customers are required to contact the local Post Office before installing the mailbox to ensure its correct placement and height at the street. Generally, mailboxes are installed at a height of 41" – 45" from the road surface to the inside floor of the mailbox or point of mail entry (locked design) and are set back 6" – 8" from front face of curb or road edge to the mailbox door.**

Contact your local USPS by calling 800-275-8777.

INSTALLING POST / BOX:

CONCRETE INSTALLATION: For a surface mount application where you have to pour the concrete pad, you will need to construct a frame consisting of 2"x4"s (wood) to make a 12"x 18" (minimum) form for the concrete to set within. Place the form in the area of which your Letter Locker is to be installed, with the 12" side parallel to the street. **IMPORTANT: If you are installing multiple units using a spreader plate, place the form /post with the long side parallel to the street.** Now dig inside the form a minimum of 12" deep. We recommend that you leave the wood frame on top of the surface grade as a mowing edge for grass and to keep water from "pooling" around the post. Mix a minimum of 2 bags of ready mix concrete with water and pour inside the wood frame. Use a 2"x 4" to "screed" and level off the concrete. Now thread a 1/2" nut onto to a "J" bolt, 1" down from the top of the "J" bolt. Place the "J" bolt thru the post, place the 1/2" washer on top of the post, then thread the last 1/2" nut on top of the washer. Tighten nut with wrench. Repeat this procedure for the other 3 - "J" bolts, nuts, and washers onto the post. (FIGURE "C".) Wait for 24 hours, and then bolt on the mailbox (FIGURE B).

SURFACE MOUNT INSTALLATION: You may exchange the “J” bolts for wedge anchors if you are installing onto existing concrete. To install on to existing concrete you must use a ½” masonry bit to drill the concrete. We highly recommended that you use a hammer drill. Use the post as your template by placing the post on the concrete where it is to be installed and mark the holes from the post. Use a **Hammer drill with a ½” masonry bit**, drill all the way through the concrete foundation. Thread the nuts on top of the redheads leaving only the tip of the threads on top of the nut. This is to prevent you from damaging the threads when you pound the redhead into the holes of the concrete you just drilled. Leave about 1-2” of the redhead above the concrete surface. Remove the nuts and place the post over your redheads. Insert the washers over the redhead. Thread and tighten the nuts on to the redheads with a ¾” **wrench or socket/ratchet**.

CONDITIONAL LIFETIME WARRANTY:

With proof of purchase, the Letter Locker is conditionally warranted for as long as you own it. The warranty extends to manufacturing defects and any failure of moving parts under normal use. However, the warranty does not extend to deliberate or accidental damage or lock replacement. This warranty does not extend to the finish, rust, or weathering. ***We recommend you install your mailbox away from sprinklers as nature may take its course and rust the mailbox.***

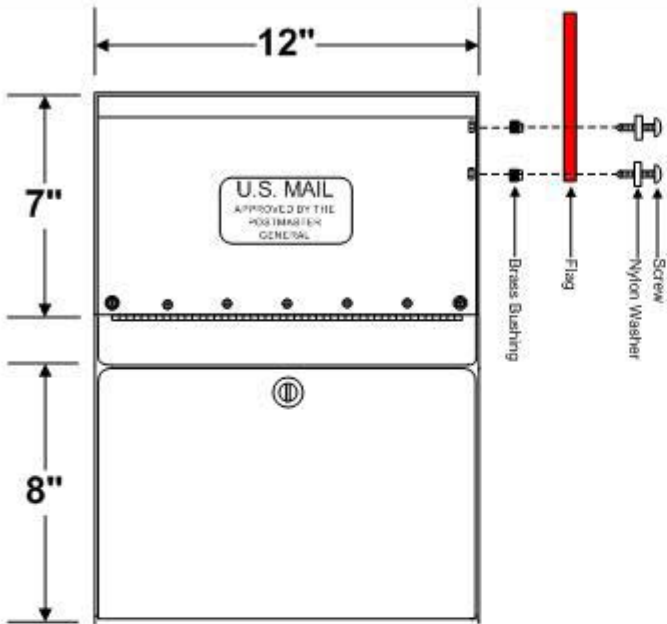

FIGURE A - Flag Installation

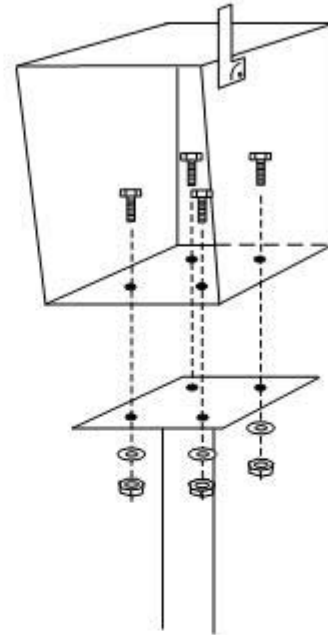

FIGURE B - Post to Box

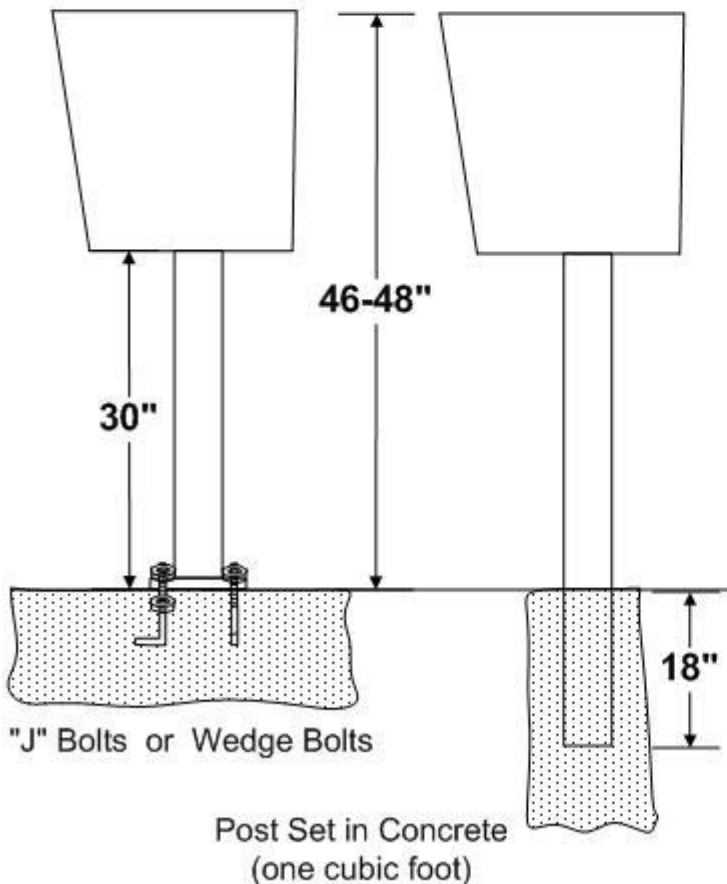
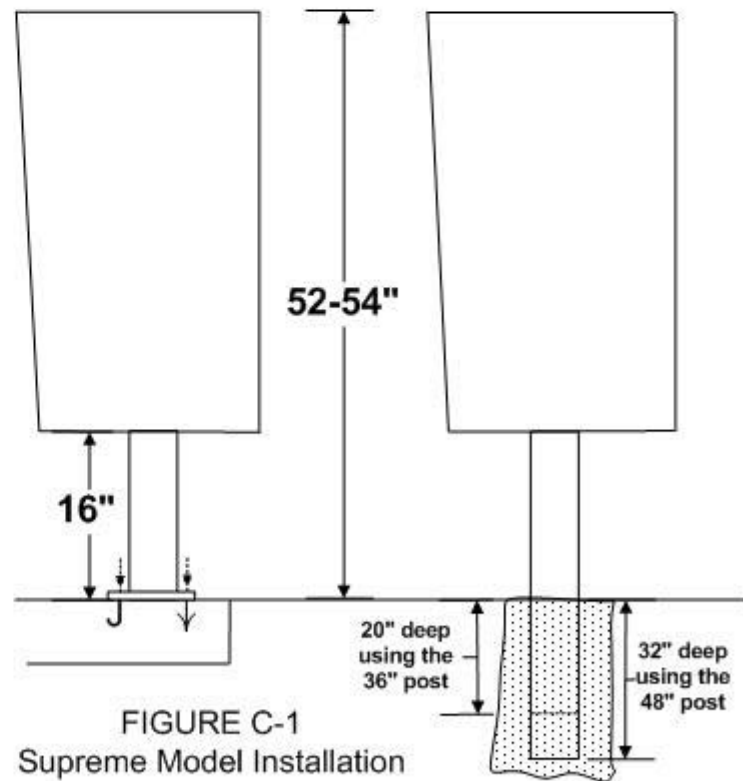

FIGURE C - Ground Installation



NOTE: All installations should be unobstructed and clear of driveways to allow safe curbside service of the mailbox by the carrier. Installations should be located on property lines on the right side of the road, in the direction of travel of the carrier. Consult with your postmaster for local instructions